

CableCop 300

Cable detection system

3-348-736-02

2/2.02



Safety notes



Caution!

Before you use the cable detection system CableCop 300, carefully read these operating instructions and follow the generally relevant *safety specifications according to DIN VDE* while operating the system.

When properly used, the safety of both the unit and the user is ensured. Their safety is not ensured, however, if the unit is misused or carelessly handled

- ⇨ Before you use an electrical device, always make a performance test to verify that the device is operating properly.
- ⇨ Preferably connect the signal generator S330 between phase and neutral. Before you connect the signal generator between phase and neutral, absolutely check the ground resistance according to DIN VDE 0100. With incorrect grounding, all parts connected to ground could carry voltage should there be a fault.
- ⇨ Prior to connecting the signal generator S330 to current or voltage circuits, check that the maximum permissible voltage for the signal generator is not exceeded.
- ⇨ Prior to connecting the transmitter T320, verify that the circuits or lines to be tested do not carry current or voltage.
- ⇨ Avoid direct contact with non-insulated live lines. Eventually wear suitable insulating gloves as well as goggles.
- ⇨ Disconnect the transmitter T320 from the measuring circuit before you replace the battery.

Contents

	Page
1 Applications, function principle	4
2 Description of the units	5
2.1 Receiver R300	5
2.2 Signal generator S330 for live lines	6
2.3 Transmitter T320 for electrically dead circuits	7
3 Measurements on live lines with the signal generator S330	8
3.1 Closed-circuit mode	8
3.2 General procedure for live lines	9
3.3 Locating switches, e.g. in a building installation	10
3.4 Locating lines in ceilings, walls and floors	10
3.5 Locating short circuits between phase and protective conductor starting from a switchboard	11
3.6 Locating ground faults in three-phase systems	12
3.7 Locating of buried lines or underground cables up to a depth of approximately 3 m	13
3.8 Tracing lines in conduits	14
3.9 Tracing coaxial cables	15
4 Measuring on electrically dead lines with the transmitter T320	16
4.1 Open circuit mode	16
4.2 General procedures for electrically dead lines	16
4.3 Locating lines and line interruptions in ceilings, walls and floors	17
4.4 Tracing the entire building installation	18
4.5 Tracing water and heating pipe lines and conduits	18
4.6 Tracing socket outlets and switches within the building installation	19
4.7 Tracing bottlenecks in tubings or conduits	20
4.8 Locating faults on an electric floor heating system	21
4.9 Locating underground lines (also in the case of a broken cable)	22
5 Technical Data	23
5.1 General information	23
5.2 Receiver R300	23
5.3 Signal generator S330	23
5.4 Transmitter T320	23
6 Maintenance	24
6.1 Battery	24
6.2 Fuse link	24
7 Repair and replacement parts service	24

1 Applications, function principle

The cable detection system CableCop 300 permits both electrically dead and live lines in circuits up to 300 V to be reliably detected. An interruption of the power supply, or a disconnection of equipment containing sensitive electronic parts, is not required. In particular, the following applications are possible:

- Location of lines in ceilings, walls and floors
- Location of line interruptions, switches and fuses
- Location of short circuits
- Location of earth faults in three-phase systems
- Detection of bottlenecks in conduits
- Tracing of underground cables that are buried in the ground up to a depth of 3 m
- Tracing of conduits, water and heating pipe lines
- Sorting of installed lines

The cable detection system consists of a signal generator for live lines and a transmitter for electrically dead lines as well as a receiver.

Signal generator and transmitter feed high-frequency electromagnetic signals into the line to be tested. Along the line, these signals are converted into acoustical and optical signals by the receiver. The signal strength is a measure for the location of the line.

Two basic operating modes are to be distinguished hereby:

Closed-circuit mode :

In this mode, live lines are tested with a potential of a maximum of 300 V to ground.

The signal current of the signal generator, for example, is fed into the phase of the line to be tested and flows back to the signal generator through neutral conductor across the transformer. This "two-pole" application corresponds to a closed circuit, whereby the energy for the generation of the signals is directly derived from the system.

In the case of a shorted line, the current flow in the circuit to be measured is interrupted, a 9-V battery can, for example, be connected into the measuring circuit as a substitute power supply.

The receiver evaluates the magnetic component of the signal.

Open-circuit mode :

In this operating mode, only electrically dead lines may be tested.

One output of the transmitter is connected to the line to be tested, the second output to ground. This "single-pole" application corresponds to the principle of a radio transmitter. The connected line hereby becomes the antenna of the transmitter, the ground serves as reference potential. The energy for the generation of the signals is provided by the internal battery.

The receiver evaluates the electrical component of the signal.

2 Description of the units

2.1 Receiver R300

The receiver R300 has two built-in detectors which receive the different signals from the signal generator for live and electrically dead lines.

These signals are indicated both optically and acoustically:

- Optically by a diode assembly with which up to 10 diodes light as a function of the signal strength. A red filter permits reading also in the case of direct incidence of sunlight.
- Acoustically by a sound generator.

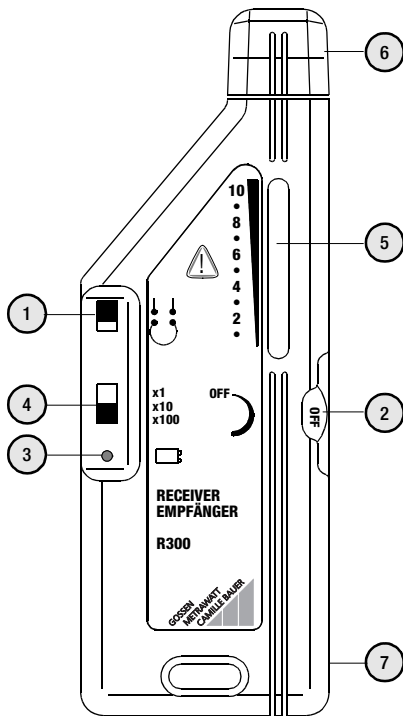

1 Mode selector switch

- Open: for transmitter T320
- Closed: for signal generator S330 or for locating broken lines

2 Thumb wheel

- ON/OFF switch
- Vernier sensitivity setting
- Stop position highest sensitivity

3 Standby LED

Lights provided the battery is inserted and charged

4 Range selector switch for coarse sensitivity setting, amplification: 1, 10 or 100

5 Diode assembly for indication of the signal strength

6 Detectors

7 Battery compartment

The battery must be inserted with correct polarity or else the compartment cannot be closed.

2.2 Signal generator S330 for live lines

The signal generator S330 sends high-frequency electromagnetic signals which the receiver R300 can locate along the line to be tested. For this purpose, the signal generator must be connected to this line as well as to a return line. The signal generator is designed for lines having AC or DC voltages from 9 to 300 V.

The signal power of this unit can be switched to a lower power so that circuits protected by residual-current circuit breakers can also be connected.

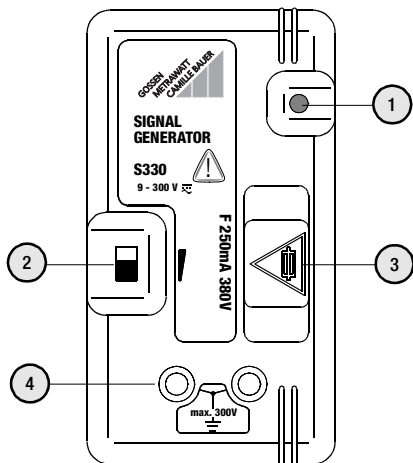

1 Standby LED

Lights when the line is live

2 Power selector switch

- Switch set to the top position: high power
- Switch set to the bottom position: low power

3 Battery compartment

When withdrawn, the signal generator is disconnected from the connected circuit

4 Sockets for test leads

2.3 Transmitter T320 for electrically dead circuits

The transmitter T320 sends high-frequency electromagnetic signals the electric or magnetic component of which can be detected along the line to be tested by the receiver R300. For this purpose, one socket of the transmitter must be connected to this line. The second socket must be connected to ground.

The unit requires a 9-V battery for the power supply.

An additional, external power source, e.g. a 24-V NiCd storage battery, leads to a increase in performance.

Storage batteries in the battery compartment are not charged via the external power source.



Caution!

The transmitter can only be used for electrically dead lines.

When using power supplies to increase the performance, only power supplies with safe electrical isolation must be used.

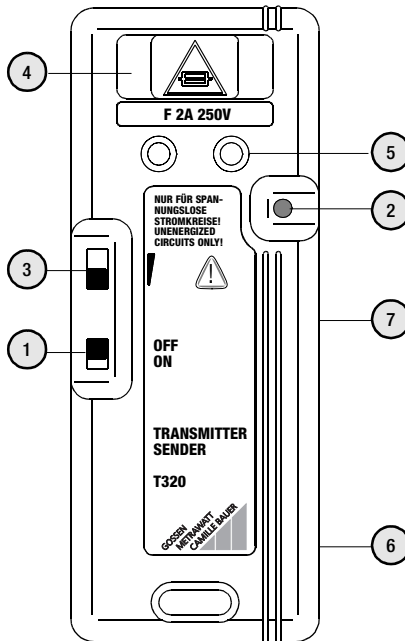

1 **ON/OFF switch**

2 **Standby LED**

Lights provided a battery is inserted and charged

3 **Power selector switch**, three-stage

4 **Battery compartment**

When withdrawn, the transmitter is disconnected from the connected circuit

5 **Sockets for test leads**

6 **Battery compartment**

The battery must be inserted with correct polarity or else the compartment cannot be closed

7 **Socket for external voltage supply for an increase in performance**

3 Measurements on live lines with the signal generator S330

3.1 Closed-circuit mode

In this operating mode, live lines are tested with a potential having a maximum of 300 V to ground.

The load current normally flows in the phase in opposite direction to the neutral conductor, see connection A. This way, the also opposite magnetic fields are weakened, causing a loss in signal strength in the receiver. The depth of detection is reduced. The same applies when the current flows back across the protective conductor, see connection B.

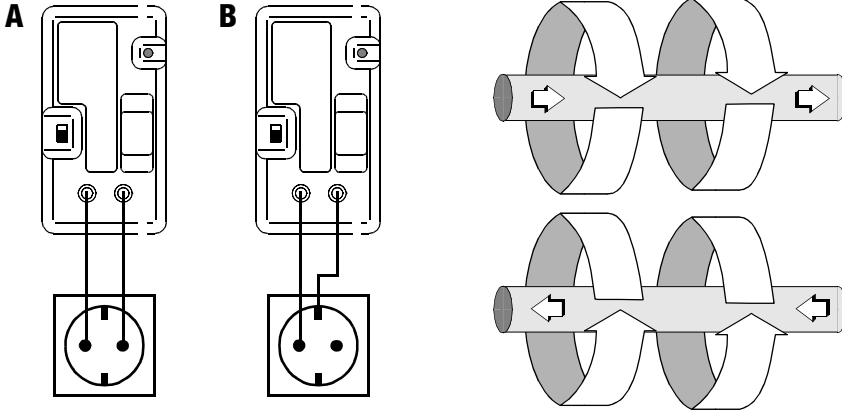

This effect is eliminated by separating the current paths. While one socket is connected to the line to be tested, the return line should not lie within the same cable or cable channel. One solution is to connect the return line to a separate ground, for example central heating, a water pipe or a sprinkler system. The other solution is to connect it to a remote outlet via a cable reel.

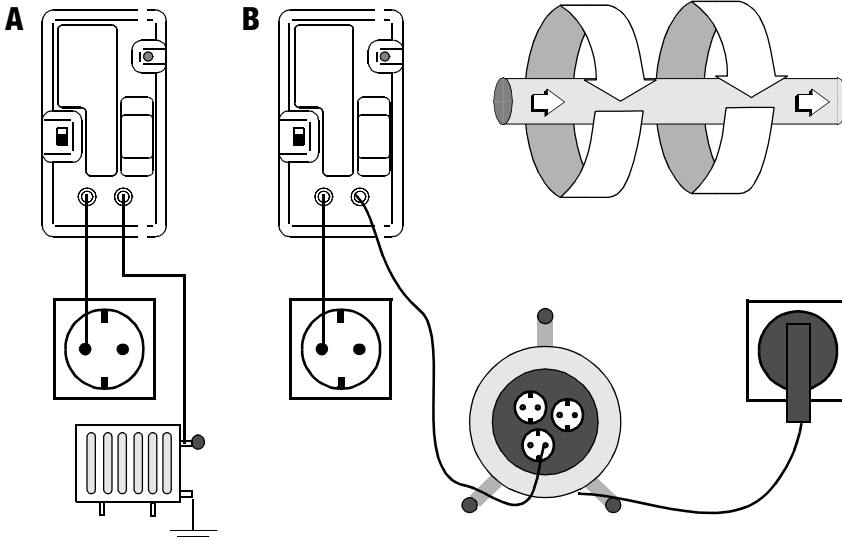

3.2 General procedure for live lines

Signal generator

- ⇨ If the measuring circuit has no residual-current circuit breaker, select the highest signal amplification.



Caution!

Before you connect the signal generator to live lines, verify that not more than 300 V DC or AC voltage are applied.

- ⇨ Connect the sockets of the signal generator in line with the application at a time. The diode of the signal generator must always light after connection of the test leads, otherwise the measuring circuit is not closed and no current flows.

Receiver

- ⇨ Insert the battery.
- ⇨ Select the *closed circuit mode*.
- ⇨ First set the range selector switch 4 to the lowest amplification x1.
- ⇨ Switch the unit on by means of the thumb wheel 1 and set the vernier sensitivity to stage 5. The standby LED must light.



Note

The sensitivity should generally be chosen in such a way that as much as possible a medium range of the diode assembly is controlled for measured signals (diodes 4 to 6 light). With control up to the tenth diode, signal fluctuations can no longer be valued unambiguously.

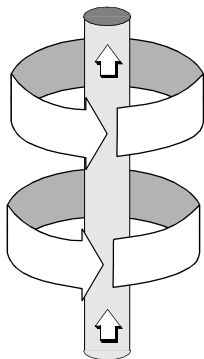

Alignment of the receiver when using the signal generator S330

The test head must be held vertical to the line as the electromagnetic component is to be captured when measuring on closed circuits.

Here, the direction of the current is shown by arrows in the conductor and the spreading direction of the electromagnetic component by circular arrows.

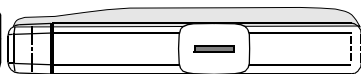

3.3 Locating switches, e.g. in a building installation

- **Connection:** Connect one socket of the signal generator to the neutral conductor, the other one to the phase of the same socket outlet.
- **Locating:** Hold the head of the receiver to every switch in the fuse box. The associated switch is located by the strongest signal.

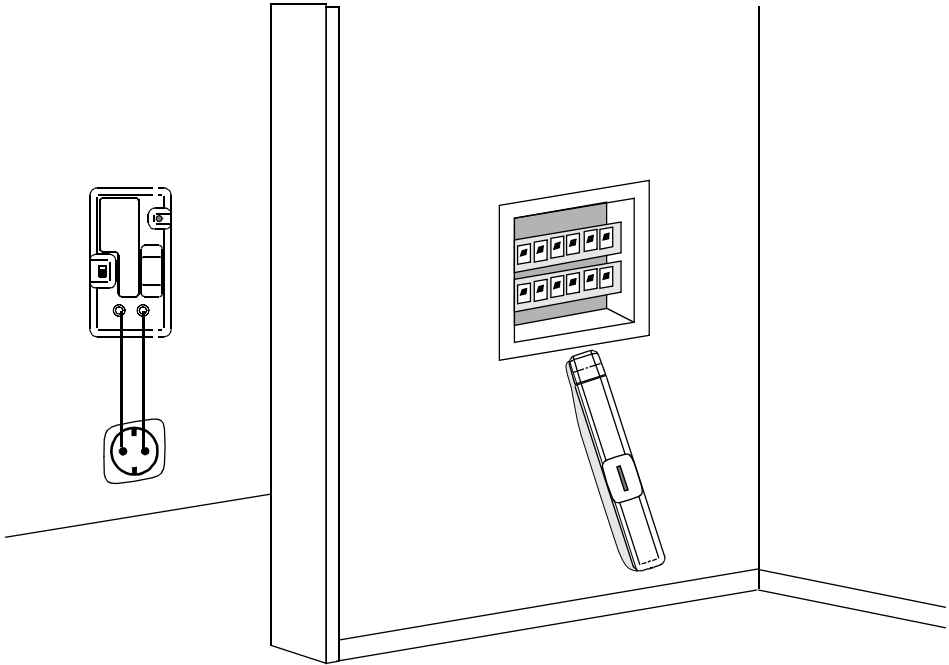

3.4 Locating lines in ceilings, walls and floors

- **Connection:** Connect one socket of the signal generator to a separate ground, the other one to the phase of a socket outlet.
- **Locating:** Move the head of the receiver in vertical direction along the point at which you expect the line.

3.5 Locating short circuits between phase and protective conductor starting from a switchboard



Caution!

Since voltage could be applied to the lines to be tested, act very carefully:

- First find out, whether voltage is applied in spite of the short circuit.
- When testing the voltage with the aid of the standby LED of the signal generator, you always should connect the ground first.
- Only when there is no voltage applied:
Connect the signal generator and the auxiliary voltage source.

- **Connection:** Connect one socket of the signal generator to ground, the second socket to the phase via an auxiliary voltage source, e.g. a battery of at least 9 V. A precondition for this is that the protective conductor of the building installation is also grounded. Alternatively, one of the test leads can be connected directly to the protective conductor of the building installation instead of to ground.
- **Locating:** Move the head of the receiver in vertical position along the point at which you expect the line. Follow the signal up to the point of the short circuit. Here, the signal disappears as the signal current flows back to the signal generator across the short circuit.

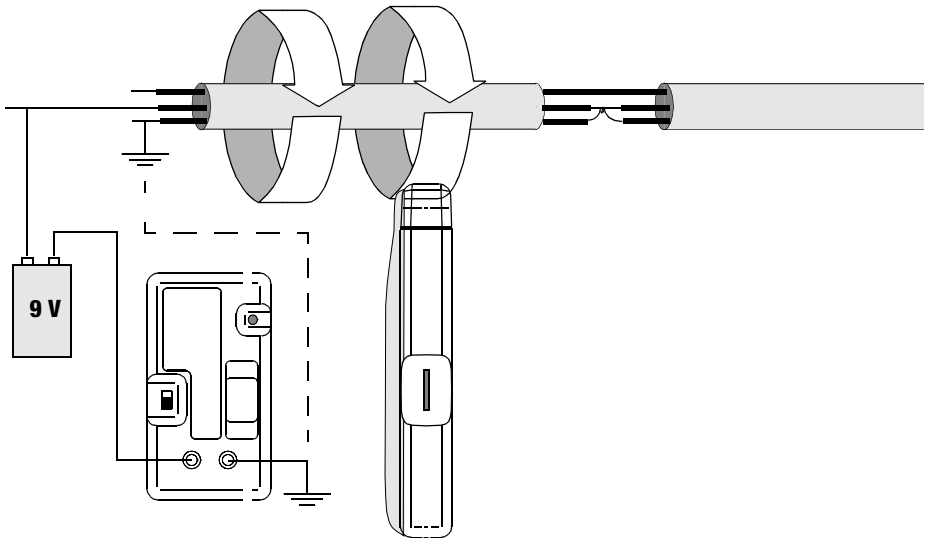

3.6 Locating ground faults in three-phase systems



Caution!

Since voltage may be applied to the lines to be tested, act very carefully:

- First find out whether voltage is applied in spite of the short circuit.
- When testing the voltage with the aid of the standby LED of the signal generator, you always should connect the ground first.
- Only when there is no voltage applied:
Connect the signal generator and the auxiliary voltage source.

- **Getting started:** First test the voltages of the individual phases to ground. The phase having the lowest voltage probably has a ground fault.
- **Connection:** Connect the socket of the signal generator to a grounded AC or DC power source, the other one to the faulty phase.
- **Locating:** Move the head of the receiver in a vertical position along the point at which you suspect the line. Follow the signal up to the point of the ground fault. From here on, the signal gets weaker as the main portion of the signal current flows back to the signal generator across the ground fault.

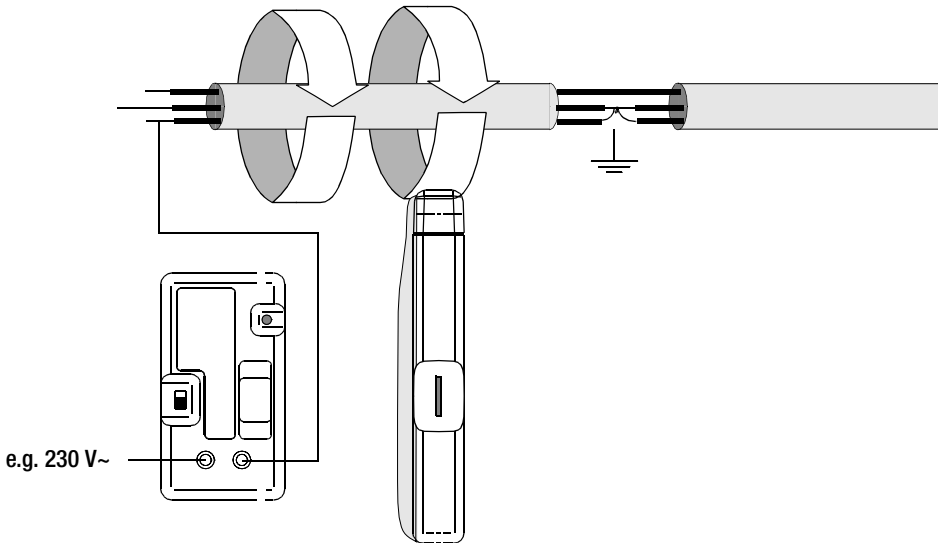

3.7 Locating of buried lines or underground cables up to a depth of approximately 3 m

- ⇨ **Connection:** Connect the socket of the signal generator to a separate ground, e.g. directly to an auxiliary earth electrode, the other one to the phase of the line running underground.
In the case of an electrically dead cable, a DC or AC source can be connected between socket and separate ground.
- ⇨ **Signal generator:** Switch the signal generator on and select the highest power.
- ⇨ **Receiver:** When searching for a line, proceed as described under "General procedures for live lines" on page 9.

The soil has a minor influence on the generated magnetic field. The signal portion returning via the limitedly conducting earth causes a weakening of the total signal strength to be measured. The signal strength generally depends upon the horizontal position, the depth of the cable, the conductivity of the soil as well as the type of soil.

Instead of a separate earth, a return line running above ground can be used, e.g. a cable-reel. This way, the signal strength can rise by half.



Note

When using a separate above-ground return line, note that the distance between forward and return line must be greater than the depth of the underground cable, but at least 2 m.

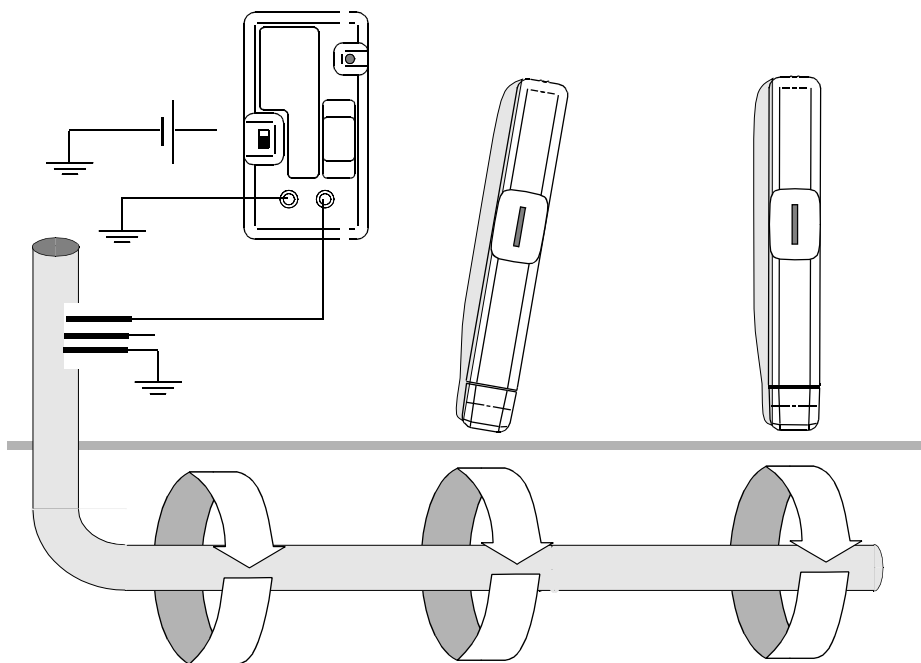

3.8 Tracing lines in conduits



Note

Note that the magnetic field on the line to be tested can also influence neighbouring conduits. That is why the receiver should be held at least 2 m away from the next switch box.

Conduits of steel having thick walls attenuate the signal to be traced while conduits of plastics or aluminium do not impair the signal.

- **Connection:** Connect one socket of the signal generator to a separate earth, the other one to a live line.
- **Locating:** When searching for a line, proceed as described under "General procedures for live lines" on page 9.

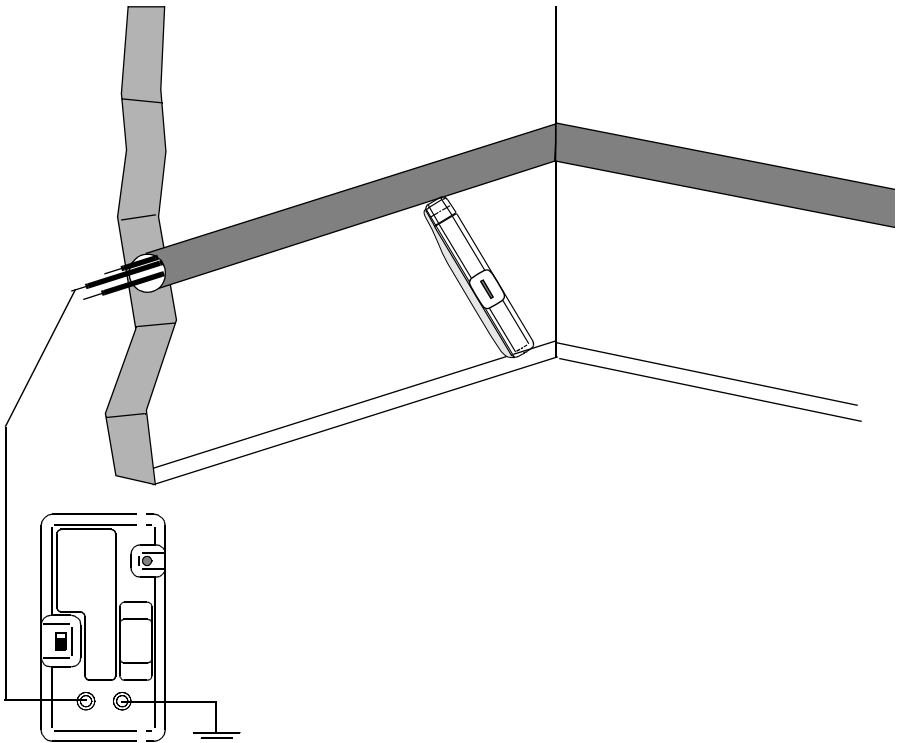

3.9 Tracing coaxial cables

- ⇨ **Connection:** Connect one socket of the signal generator to the shield of the coaxial cable and the other one to a grounded DC or AC source.
- ⇨ **Locating:** When searching for a line, proceed as described under "General procedures for live lines" on page 9.



Caution!

Make sure that the shield of the coaxial cable is applied to ground potential on the other end.

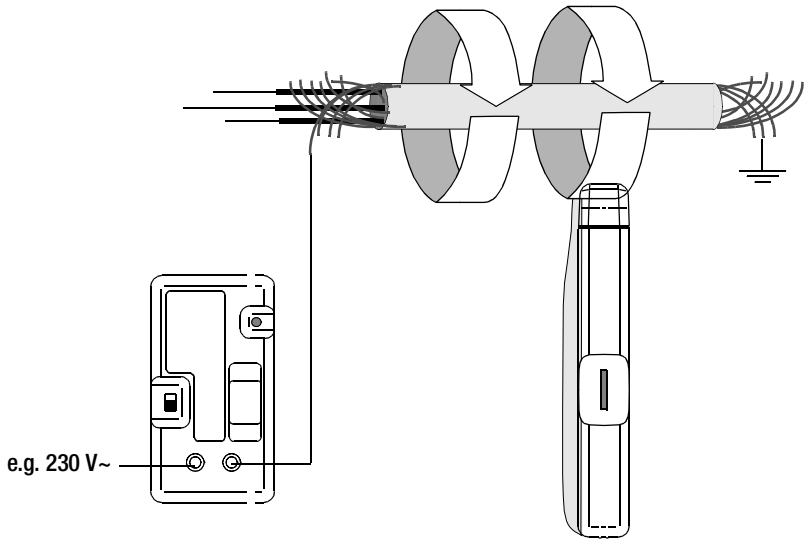

4 Measuring on electrically dead lines with the transmitter T320

4.1 Open circuit mode ↓ ↓

Only lines carrying no current and no voltage must be tested in this operating mode.

Connect one output of the transmitter to the line to be tested, the second output to ground.

4.2 General procedures for electrically dead lines

Transmitter

- ⇨ Install the battery.
- ⇨ Select a medium signal amplification.
- ⇨ Switch the transmitter on. The standby LED must light.



Caution!

Make sure that the line to be measured is electrically dead.

- ⇨ Connect the sockets of the transmitter in line with the application at a time.

Receiver

- ⇨ Install the battery.
- ⇨ Select the *open circuit mode*.
- ⇨ At first set the range selector switch 4 to the lowest amplification x1.
- ⇨ Switch the unit on via the thumb wheel 1 and set the vernier sensitivity to stage 5.
The standby LED must light.



Note

The sensitivity should generally be chosen in such a way that for the signals measured a medium range of the diode assembly is controlled (diodes 4 and 6 light).
With control up to the tenth diode, signal variations can no longer be valued unambiguously.

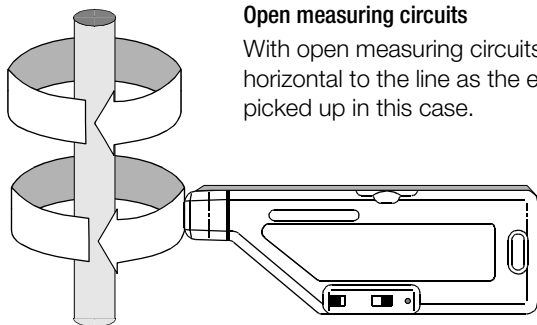

Open measuring circuits

With open measuring circuits, the probe head must be held horizontal to the line as the electric component of the signal is picked up in this case.

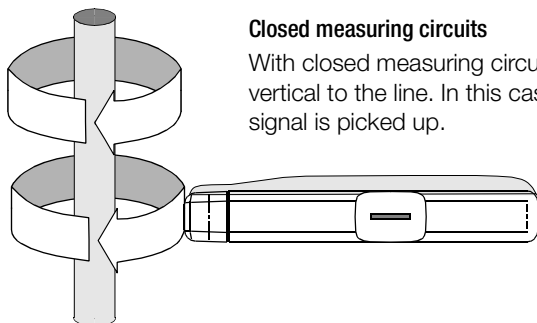

Closed measuring circuits

With closed measuring circuits, the probe head must be held vertical to the line. In this case, the magnetic component of the signal is picked up.

4.3 Locating lines and line interruptions in ceilings, walls and floors



Caution!

Make sure that the line to be measured is electrically dead.

- ⇒ **Connection:** Connect one socket of the transmitter to ground, the other one to the line to be tested.
- ⇒ **Transmitter:** Switch the transmitter on and select the required power.
- ⇒ **Receiver:** Select the *open circuit mode*. When searching for the line, proceed as described under "General procedures for electrically dead lines" on page 16. The signal strength decreases at the point of interruption and beyond.



Note

When searching for line interruptions in multiwire cables, note that all wires not used must be grounded. This is to reduce capacitive couplings into the other lines. To locate the interruption, the transient resistance must be higher than 100 k Ω . Note that the high-frequency signals for locating of lines are shielded in unfavourable cases, e.g. by metallic foils or conduits.

4.4 Tracing the entire building installation



Caution!

At first, disconnect the electric system on principle. *

- ⇒ **Getting started:** Remove the bridge between PE and N in the main distribution board.
 - ⇒ **Connection:** Connect one socket of the transmitter to PE and the other one to the N terminal in the main distribution board.
 - ⇒ **Transmitter:** Switch the transmitter on and select the required power.
 - ⇒ **Receiver:** Choose the *open circuit mode*. When searching for the line, proceed as described under "General procedures for electrically dead lines" on page 16. You now can trace the neutral conductor in the entire building installation.
-



Caution!

The connection between PE and N must absolutely be restored after the measurement. *

4.5 Tracing water and heating pipe lines and conduits



Caution!

At first, disconnect the electric system on principle. *

- ⇒ **Getting started:** Disconnect the pipes from the ground connection
 - ⇒ **Connection:** Connect one test socket to ground, e.g. to the foundation earth electrode or to the safety contact of the socket outlet, the other socket to the corresponding pipe.
 - ⇒ **Transmitter:** Switch the transmitter on and select the required power.
 - ⇒ **Receiver:** Select the *open circuit mode*. When searching for the line, proceed as described under "General procedures for electrically dead lines" on page 16.
-



Caution!

The original ground connection must absolutely be restored after the measurement. *

* Must only be performed by an expert who, based on his education, knowledge and experience as well as the knowledge of relevant specifications, can understand the work he is charged with and who can recognize eventual dangers.

4.6 Tracing socket outlets and switches within the building installation



Caution!

Disconnect the circuit by interruption in the distribution board.

- ◇ **Precondition:** Neutral conductor and protective conductor each must be connected.
- ◇ **Connection:** Connect one socket of the transmitter to the protective conductor, the other one to the phase.
- ◇ **Transmitter:** Switch the transmitter on and select the required power.
- ◇ **Receiver:** When searching for the line, proceed as described under "General procedures for electrically dead lines" on page 16.

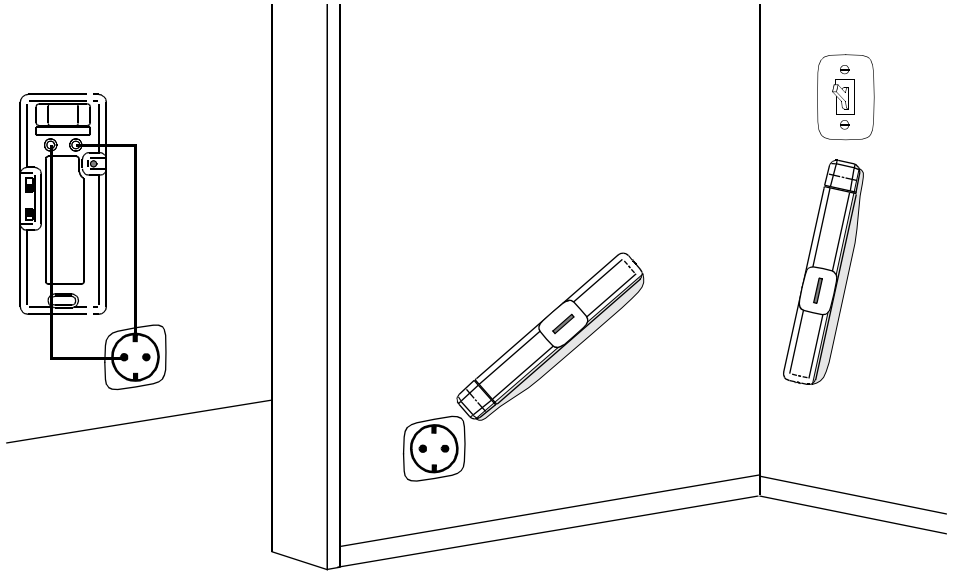

4.7 Tracing bottlenecks in tubings or conduits



Caution!

Disconnect existing circuits in the conduit. The circuits must be grounded.

- **Getting started:** Disconnect the conduits from the ground connection
- **Connection:** Connect one test socket to ground, e.g. to the foundation earth electrode or the safety contact of the socket outlet, the other socket to the metal spiral.
Instead of a metal spiral, a non-conducting spiral can be used with the aid of which a copper wire can be pushed in up to the bottleneck.
- **Transmitter:** Switch the transmitter on and select the required power.
- **Receiver:** Choose the *open circuit mode*. When searching for the line, proceed as described under "General procedures for electrically dead lines" on page 16. The signal strength decreases at the bottleneck.

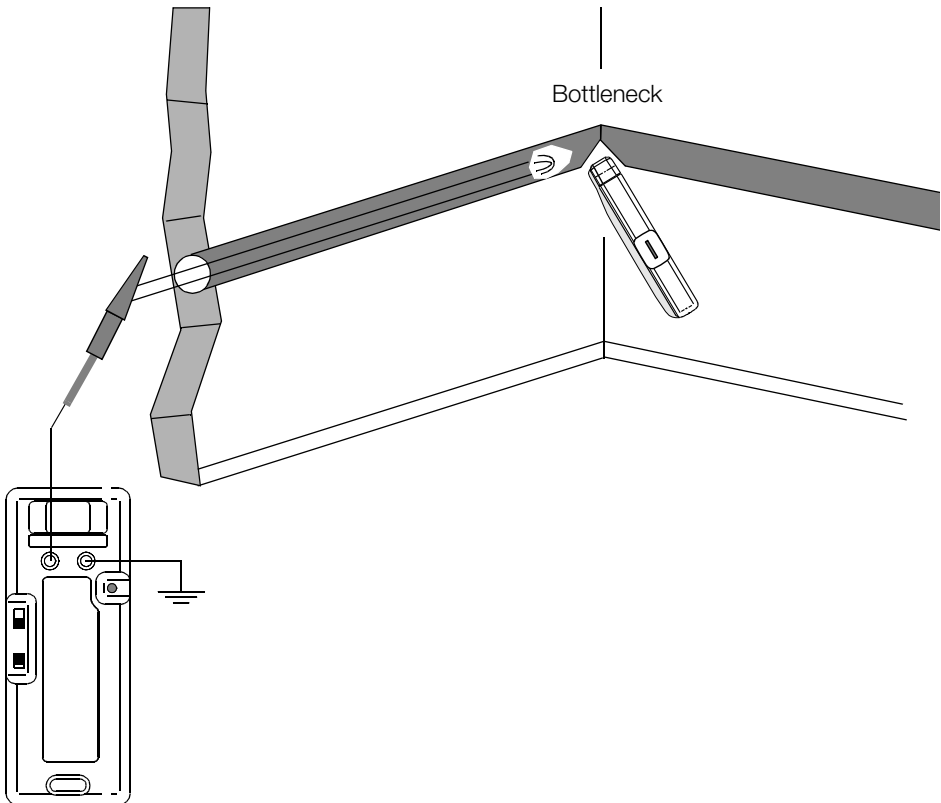

4.8 Locating faults on an electric floor heating system



Caution!

Make sure that the heating wire to be measured carries neither current nor voltage.

- ◇ **Getting started:** Interrupt the connection of the shield matting and/or the coaxial shield braiding to ground, if available.
- ◇ **Connection:** Connect one test socket to ground, e.g. to the safety contact of the socket outlet, the other socket to the heating wire.
- ◇ **Transmitter:** Switch the transmitter on and select the required power. Take into account here that the corresponding shielding causes a signal attenuation.
- ◇ **Receiver:** When searching for the line, proceed as described under "General procedures for electrically dead lines" on page 16. The signal strength decreases when the broken wire is reached.

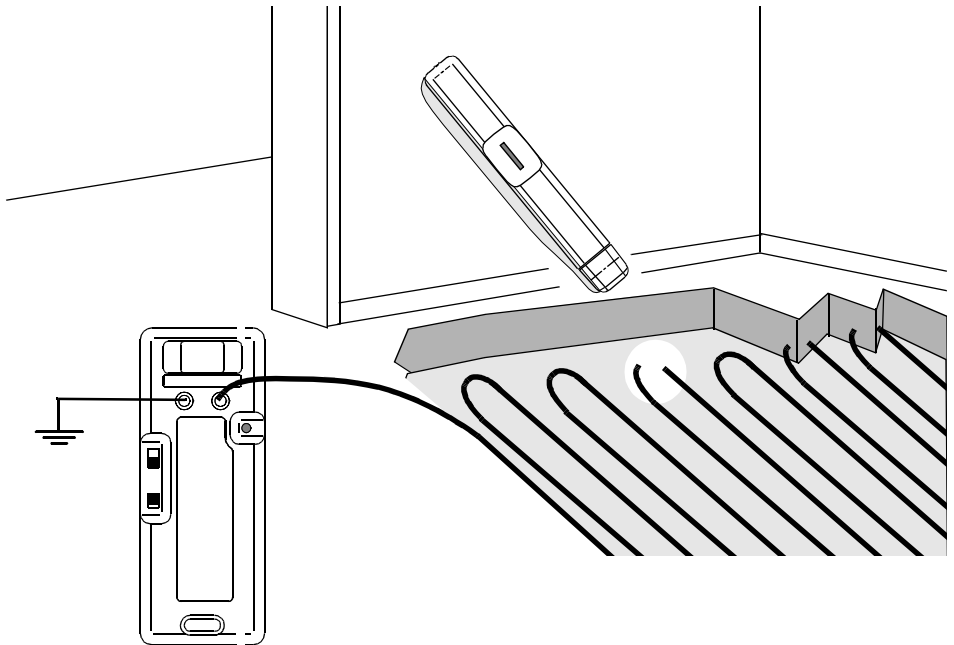

Caution!

The connection of the shield matting and/or the coaxial shield braiding to ground must absolutely be restored after the measurement.

4.9 Locating underground lines (also in the case of a broken cable)



Caution!

Make sure that the line to be measured or the circuit to be measured is electrically dead.

When using power supplies to increase the performance, only power supplies with safe electrical isolation must be used.

- **Connection:** Connect one socket of the transmitter to the line running underground and the other one to the ground of the circuit to be tested. Neutral conductor and protective conductor must also be grounded to prevent capacitive couplings into the transmitting signal.
- **Transmitter:** Switch the transmitter on and select the required power. Depending upon the location of the line, it may be required to increase the power of the transmitter via an external 24 V voltage source.
- **Receiver:** Select the *closed circuit mode* here, regardless of the line being broken or not. Otherwise, search for the line as described under "General procedures for electrically dead lines" on page 16.

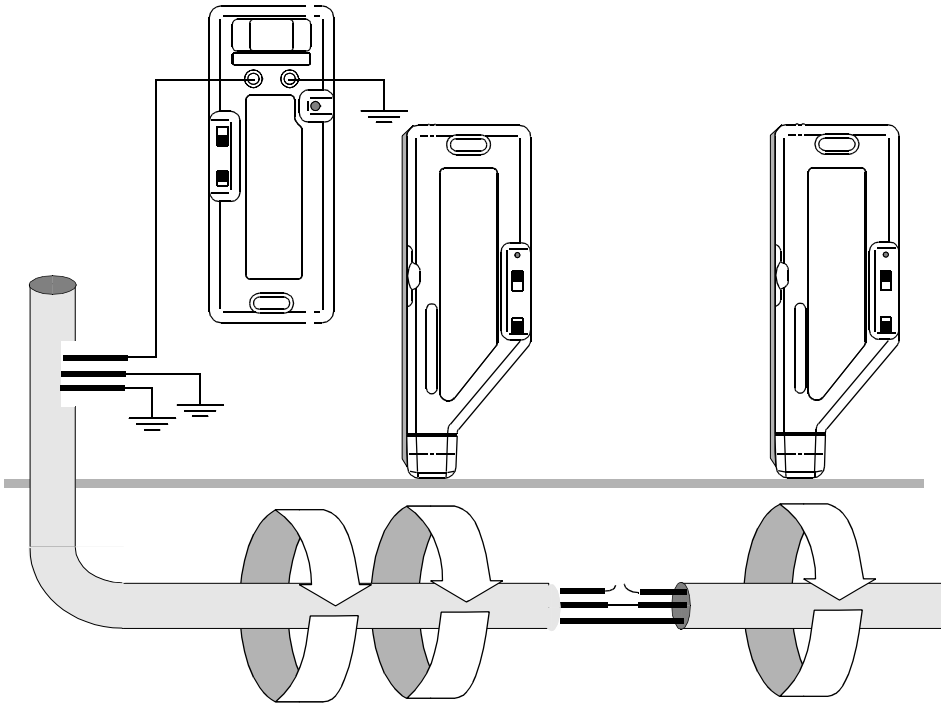



Even in the case of a broken cable, a sufficient signal current for location of the line normally flows through the soil here. If, however, no current flow takes place, it is also possible to be measured in the *open circuit mode*.

5 Technical Data

5.1 General information

Operating temperature	-20 °C to +50 °C
Storage temperature	-40 °C to +65 °C
Generic emission	IEC/EN 61 326-1
Generic immunity	IEC/EN 61 326/A1

5.2 Receiver R300

Mode selection	 closed measuring circuit, live line max. 300 V  open measuring circuit, electrically dead line
Range selection	Amplification: x 1, x 10 or x 100 with vernier amplification setting via thumb wheel
Battery	9 V flat cell battery 6LR61 or 6LF22 to IEC 68-2
Display	10 LED display with chroma filter
Material of case	ABS 911 low inflammability
Weight	176 g incl. battery

5.3 Signal generator S330

Operating voltage	9 V ... 300 V AC/DC
Operating frequency	32 768 kHz
Signal	Clock cycle 0.5 s; 2 pulses of 0.0625 s duration each
Power selection	Amplitude selectable Low (< 35 mA) High (70 mA)
Power consumption	Peak value 4 mA _S 6 mA _S
Fuse	Quick-acting, 250 mA/380 V, 6.3 x 32 mm
Material of case	ABS 911 low inflammability
Weight	108 g

5.4 Transmitter T320

Operating frequency	32 768 kHz	
Signal	Clock cycle 0.5 s; 2 pulses of 0.0625 s duration each	
Power selection	Selectable Low Medium High	
Power consumption	9 V lead	Peak value 3.0 A _S 1.8 A _S 1.0 A _S
	24 V lead	Average 187 mA 106 mA 62.5 mA
		Peak value 18.0 A _S 6.0 A _S 3.0 A _S
Voltage	9 V lead	Average 500 mA 312 mA 175 mA
	24 V lead	Peak value 6.5 V _S 13.0 V _S 31.0 V _S
		Peak value 22.0 V _S 45.0 V _S 105.0 V _S
Fuse	Quick-acting, 2 A/250 V, 6.3 x 32 mm	
Battery	9 V flat cell battery 6LR61 or 6LF22 to IEC 68-2	
Material of case	ABS 911 low inflammability	
Weight	182 g incl. battery	

6 Maintenance

6.1 Battery

If the standby LED of transmitter T320 or receiver does not light after turn-on, the battery is probably discharged. A discharged or deteriorating battery must not be left in the battery compartment.

Replacing the battery

- ⇨ Disconnect the transmitter from the line.
- ⇨ Press against the strap of the battery compartment and lift it upwards. Replace the battery. The battery compartment can only be closed again when the battery is installed with correct polarity.

6.2 Fuse link

The fuse holders of signal generator and transmitter are arranged at the front and are marked with the battery symbol.

Replacing the fuse link

- ⇨ Disconnect the signal generator from the line.
- ⇨ Withdraw the fuse holder and replace the fuse.



Caution!

Absolutely verify that only the specified fuse is installed! The use of a fuse of other cutout characteristics, other nominal current or other switching capacity endangers the user, and moreover, there is danger of damaging protective diodes, resistors or other components.

7 Repair and replacement parts service

When you need service, please contact:

GOSSEN-METRAWATT GMBH
Service-Center
Thomas-Mann-Strasse 20
90471 Nürnberg, Germany
Phone +49 911 86 02 - 410 / 256
Fax +49 911 86 02 - 2 53
e-mail service@gmc-instruments.com

This address is only valid in Germany.

Please contact our representatives or subsidiaries for service in other countries.

Printed in Germany · Subject to change without notice

GOSSEN-METRAWATT GMBH
Thomas-Mann-Str. 16-20
D-90471 Nürnberg
Phone +49 911 8602-0
Fax +49 911 8602-669
e-mail: info@gmc-instruments.com
<http://www.gmc-instruments.com>

GOSSEN
METRAWATT
CAMILLE BAUER